

# SHURFLO® 380 - 1000 GPH BILGE PUMPS

## INSTALLATION & MAINTENANCE MANUAL

Quality bilge pumps you can trust. SHURflo bilge pumps are built for the harsh marine environment to withstand the toughest conditions. Standard with 3' Tinned Wire Assembly for above waterline installations and water cooled motors for extended life.



### FEATURES

- Quick-disconnect base plate for easy installation
- Nylon Impeller
- Submersible
- 3 ft. tinned power leads to insure operation in the wettest conditions.
- Water cooled motor to insure long life
- Easy transom mount base plate

### OPERATION

**MANUAL MODE:** When brown wire from switch is not hooked up, the pump float switch is bypassed. To turn pump on, turn switch on. If pump does not turn on, turn switch off, check power, fuses, connections, wires. Retry. If pump does not turn on, check pump motor. When the water level is above the float switch, the pump will automatically start. If the float becomes jammed with debris, the pump will **NOT STOP** running. Turn the pump switch to the **OFF** position. Remove the debris. Reset switch to the automatic or manual **ON** position. Test.

**SWITCH TEST:** Turn power ON to pump switch and test.

**DO NOT run pump dry. Always test pump and switch before leaving dock.**

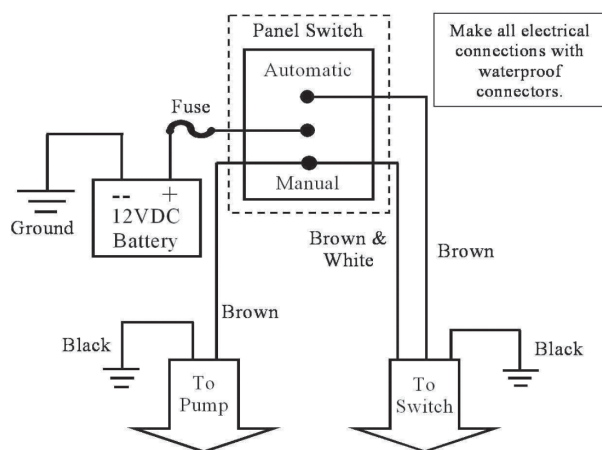

Typical Electrical Installation with Pump & Switch

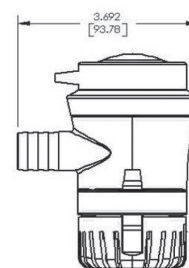
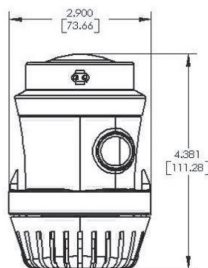

### SPECIFICATIONS

- Pump Type:** Centrifugal
- Port Outlet:** 3/4" to 1-1/8" Barb depending on model
- Motor:** DC Permanent Magnet
- Lead wires:** 3 ft. tinned, 16 AWG
- Fuse:** See label for fuse size
- Duty Cycle:** Continuous Duty
- Control:** No control
- Approvals:** Ignition protected, ISO 8846, CE

### INSTALLATION

- LOCATION:** Locate pump at deepest position in the bilge. Keep away from high heat source; engine, etc.
- MOUNTING:** Mount quick-disconnect bracket to hull or pad with stainless steel screws. Mount switch if equipped. **Do not drive screws through hull!**
- TUBING:** Route smooth I.D. discharge tubing to a thru-hull fitting well above the water line. **AVOID AIRLOCK & MAXIMIZE PERFORMANCE.** Avoid any sagging or loops in the tubing. Tubing must go up from pump to thru-hull.

### ELECTRICAL

- Use 16GA wire for all circuits. If installation is over 20 feet, use 14GA wire. Brown pump wire must be hooked to positive power for maximum flow. Wire is designed to prevent corrosion.
- PANEL SWITCH:** Attach all wires to UL Marine approved duty switch with auto-off-manual, rated at or above 10 amps.
- FUSE:** Install a fuse per pump label specifications.
- CONNECTIONS:** Wire connections should be made above highest possible water level. Seal wire connections to prevent corrosion and electrolysis.

## WARNING

Do not pump oil, diesel fuel, gasoline or other flammable liquids with this pump. This pump does not prevent the discharge of oil or other chemicals into the water. Please take appropriate measures to prevent discharging oil or other chemicals and safeguard the environment. Always disconnect power

before servicing pump. Always use fuse size specified in specifications. These bilge pumps are designed to evacuate standing bilge water only. These pumps may not prevent boat sinkage due to storms, rough weather, unsafe boating, improper installation procedures or hull damage.

## CLEANING

**IMPELLER:** Snap pump out of base plate by pressing in the tabs. Clean debris and snap back in place. Test unit.

**SWITCH:** Remove debris or build-up. Reinstall switch and test unit.

**SWITCH TEST:** Turn power on to pump switch.

**WIRING:** Check all wire connections regularly. Repair sign of corrosion.

Model #	FLOW GPH [LPH]			TECHNICAL DATA				
	0' [0m]	3' [1m]	6' [2m]	Max. Head ft. [m]	Max. Amps	Fuse	Outlet Port	Dims.
355-020-10	380 [1438]	340 [1157]	240 [817]	7.5 [2.2]	1.7	2.5	3/4"	4-1/2" x 3"
355-010-10	500 [1892]	430 [1464]	270 [918]	7.5 [2.2]	1.8	2.5	3/4"	4-1/2" x 3"
355-110-10	700 [2649]	600 [2043]	500 [1702]	10 [3]	3.2	5	3/4"	4-1/2" x 3"
355-100-10	1000 [3048]	840 [2861]	650 [2214]	11 [3.3]	3.4	6	1-1/8"	4-1/2" x 3"

Specifications given at design voltage 13.6 VDC per ABYC recommendations.

**Pump Power leads:** 3 ft. [0.9 M] #16 tinned stranded copper wire to minimize corrosion. Positive (+) brown; Ground (-) black Switch Leads (If equipped with SHURFLO Float Switch): Automatic (+) brown; Manual (+) brown & white; Ground (-) black

**Temperature limits:** 33°F-140°F [0°C-60°C]. All models rated for continuous duty.

**Approvals:** Ignition Protected, ISO 8846, ABYC, NMMA Type Accepted, CE.

Attach tubing with DOUBLE S.S. hose clamps.  
All below water line connections should have double clamps.

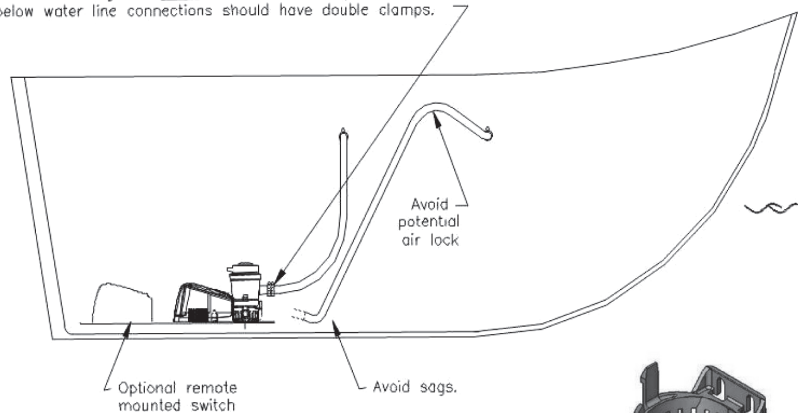

## TROUBLESHOOTING

### NO WATER PUMPED/PUMP NOT RUNNING

- ✓ Reset pump switch. Blown fuse.
- Reversed polarity damaged switch board. Wire connections. Impeller or float switch plugged with debris.

### REDUCTION IN WATER FLOW

- ✓ Impeller/screen plugged with debris. Pinch/clogged discharge tubing. Discharge tubing sagging below pump causing air lock. Tubing must go up from pump to thru-hull fitting. Low voltage to pump; check battery/wire connections.

### LOW FLOW

- ✓ Polarity reversed; check wiring. Use only smooth bore (I.D.) discharge tubing. Is thru-hull fitting I.D. smaller than pump discharge port?

### RUNS CONTINUOUSLY

- ✓ Check boat for leaks; Clean accumulated debris from float mechanism.



### FLUID MANAGEMENT SOLUTIONS

3545 HARBOR GATEWAY SOUTH, SUITE 103, COSTA MESA, CA 92626, (800) 854-3218 WWW.SHURFLO.COM

All Pentair trademarks and logos are owned by Pentair, Inc. All other brand or product names are trademarks or registered marks of their respective owners. Because we are continuously improving our products and services, Pentair reserves the right to change specifications without prior notice. Pentair is an equal opportunity employer.