

MARINE PRODUCT DATA SHEET

OEM: 277-3100 (3" Blower)
AFTERMARKET: 277-3110 (3" Blower)

APPLICATION

Ventilation for engine compartments, bilges, galleys and head closets

BLOWER

Type: In-line Blower
Port (Output): 3" Barb
Port (Inlet): 3" Barb
Fan: 6 Blade

ELECTRICAL

Motor: 12VDC Permanent Magnet, Continuous Duty
Protection: Need External Fuse (Not supplied)
Leads: 12 In [0.3M] Tinned, 16 AWG
Fuse: 5 Amp Recommended
Control: No Control

MATERIALS

Housing: ABS
Fan: Nylon 6/6 30% Glass Filled

APPROVALS

ISO 9097 Marine, Ignition Protected, CE,
USCG 183.410 Compliant, NMMA Type Accepted, ABYC

SHIPPING

Approx. Net Weight: 0.8 Lbs. [0.36 Kg] each
Approx. Carton Weight: 29 Lbs. [13.15 Kg]
Blowers in Carton: 30
Approx. Carton Size: 4"L x 18"W x 11" H
[61cm x 46 cm x 28]

RELATED DOCUMENTS

Catalog: MS-030-140
Applications Spec Guide: MS-020-005
Installation Manual: 911-723
Aftermarket Warranty: 911-1045



SHURflo has developed a unique nylon fan that includes 6 blades to ensure high performance and efficient ventilation. Installation of the Yellowtail™ Blower is made easy with extended barbs and slotted mounting bracket.

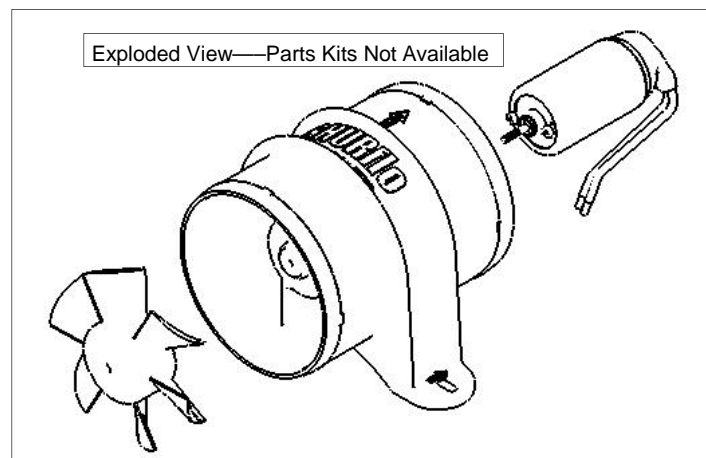

Performance at Nominal Voltage 12 VDC

3" Blower Model Series 277-3XXX 12 VDC

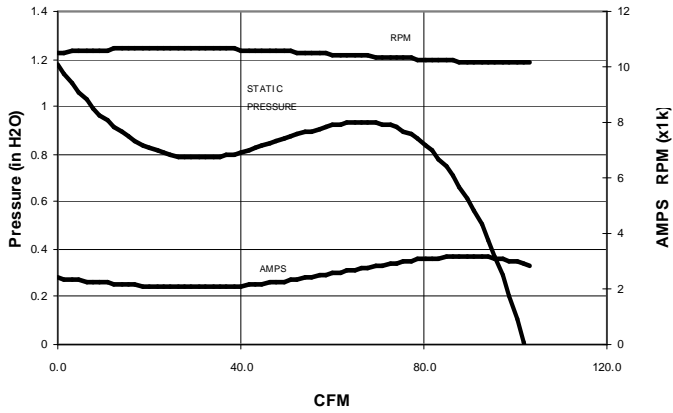

Performance at Rated Voltage (113.3%) 13.6 VDC

3" Blower Model Series 277-3XXX 13.6 VDC

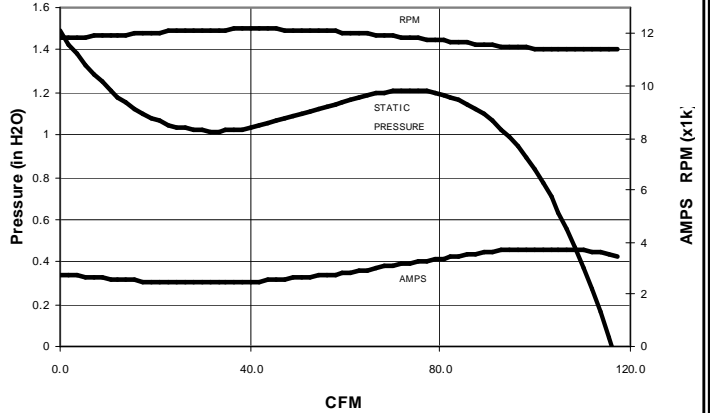

DIMENSIONS [mm]

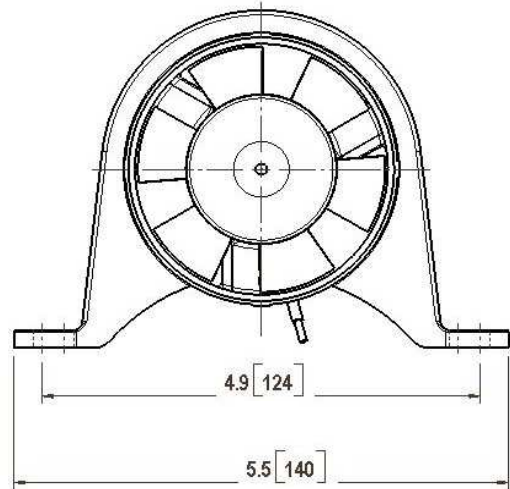
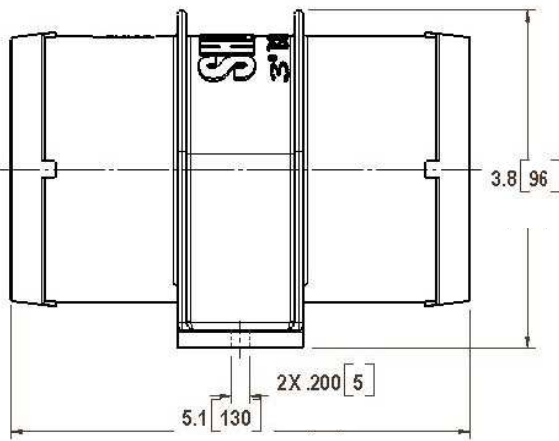

WATER PURIFICATION

3545 Harbor Gateway South, Suite 103, Costa Mesa, CA 92626, (800) 854-3218 www.SHURFLO.com

All Pentair trademarks and logos are owned by Pentair, Inc. All other brand or product names are trademarks or registered marks of their respective owners. Because we are continuously improving our products and services, Pentair reserves the right to change specifications without prior notice. Pentair is an equal opportunity employer.